

**SPECIFICATIONS:**

- FREQUENCY: ..... 0.5 GHz TO 18 GHz
- INSERTION LOSS: ..... REFLECTIVE: 3.0db  
..... ABSORPTIVE: 3.75db
- ISOLATION: ..... 0.5 GHz TO 2 GHz: 60db  
..... 2 GHz TO 18 GHz: 70db
- VSWR: ..... REFLECTIVE IN/OUT: 2.0:1  
..... ABSORPTIVE IN/OUT: 2.0:1  
..... ABSORPTIVE OUT/OFF: 2.0:1
- SPEED: ..... RISE: 10ns TYPICAL, 15ns MAX.  
..... FALL: 10ns TYPICAL, 15ns MAX.  
..... DELAY ON: 75ns TYPICAL, 100ns MAX.  
..... DELAY OFF: 75ns TYPICAL, 100ns MAX.
- POWER INPUT: ..... (CW)+20dBm (STANDARD), +10 dBm (HIGH SPEED)
- SURVIVAL POWER: ..... 1 WATT CW, 10 WATTS PEAK 1 usec
- CONTROL: ..... TTL LOGIC "0"=ON "1"=OFF
- POWER SUPPLY: ..... +5V @ 200 mA MAX.  
..... -5V @ 75mA MAX.(REFLECTIVE)  
..... 100mA MAX.(ABSORPTIVE/NON-REFLECTIVE)

**OPTIONS:**

- INDEPENDENT CONTROL WITH SOLDER PIN STANDARD
- DEC-SP ..... 2 BIT DECODER WITH SOLDER PIN
- 10M18 ..... 10 MHz TO 18 GHz (INSERTION LOSS INCREASES BY 1.5db AT 10 MHz AND 0.5db AT 18 GHz)
- 100M18 ..... 100 MHz TO 18 GHz (INSERTION LOSS INCREASES BY 1.5db AT 100 MHz AND 0.5db AT 18 GHz)
- 118 ..... 1 GHz TO 18 GHz (NO CHANGE IN INSERTION LOSS)
- 218 ..... 2 GHz TO 18 GHz (NO CHANGE IN INSERTION LOSS)
- 412 ..... 4 GHz TO 12.4 GHz (NO CHANGE IN INSERTION LOSS)
- 618 ..... 6 GHz TO 18 GHz (NO CHANGE IN INSERTION LOSS)
- 1218 ..... 12 GHz TO 18 GHz (NO CHANGE IN INSERTION LOSS)
- 100M20 ..... 100 MHz TO 20 GHz (INSERTION LOSS INCREASES BY 1.5db AT 100 MHz AND 1.0db AT 20 GHz)
- 220 ..... 2 GHz TO 20 GHz (INSERTION LOSS INCREASES BY 1.0db AT 20 GHz)
- 1020 ..... 10 GHz TO 20 GHz (INSERTION LOSS INCREASES BY 1.0db AT 20 GHz)
- B01 ..... -12V POWER SUPPLIES
- B02 ..... -15V POWER SUPPLIES
- B03 ..... REVERSE LOGIC "1"=ON "0"=OFF
- B04 ..... DRIVERLESS, CURRENT CONTROLLED
- B05 ..... HIGH SPEED, TURNON/TURNOFF 25 nsec MAXIMUM WHEN APPLICABLE
- B06 ..... HIGH POWER - SPECIFY CW POWER, PEAK POWER, PULSE WIDTH, DUTY CYCLE, RF FREQUENCY AND BANDWIDTH
- B07 ..... CUSTOM DESIGNED PRODUCT- SPECIFY INITIALS OF CUSTOMER
- B08 ..... LOW VIDEO TRANSIENTS - SPECIFY VIDEO BANDWIDTH
- B09 ..... LOW INSERTION LOSS VERSION
- B10 ..... HIGHER ISOLATION VERSION

**ENVIRONMENTAL RATINGS:**

- TEMPERATURE: ..... -55°C TO +85°C (OPERATING)  
..... -65°C TO +125°C (STORAGE)
- HUMIDITY: ..... MIL-STD-202F, METHOD 103B COND. B
- SHOCK: ..... MIL-STD-202F, METHOD 213B COND. B
- VIBRATION: ..... MIL-STD-202F, METHOD 204D COND. B
- ALTITUDE: ..... MIL-STD-202F, METHOD 105C COND. B
- TEMPERATURE CYCLE: ..... MIL-STD-202F, METHOD 107D COND. A

NOTE: THE ABOVE SPECIFICATIONS ARE SUBJECT TO CHANGE OR REVISION

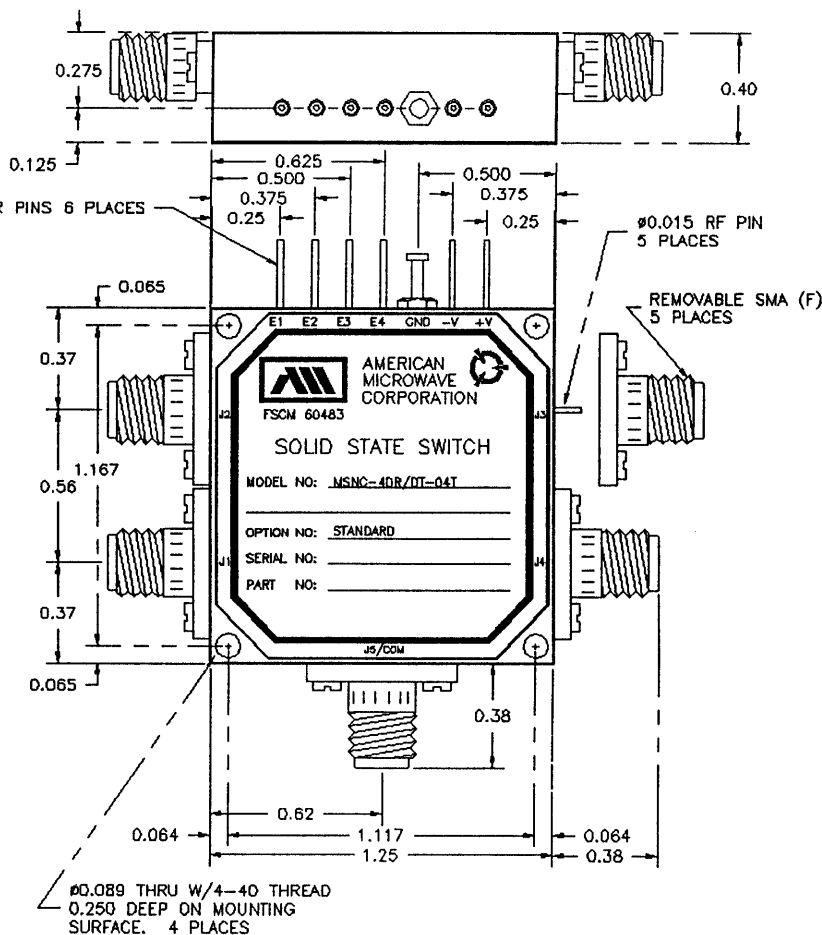
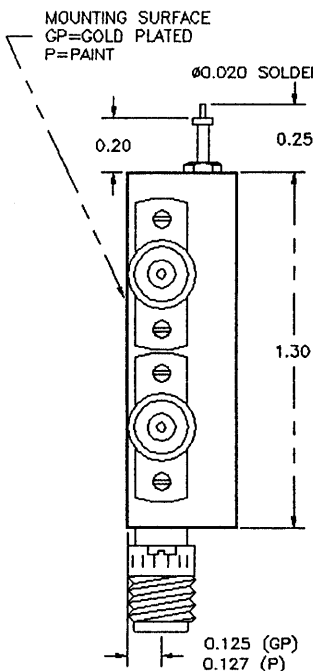

NOTE:

DR=WITH DRIVER, REFLECTIVE

DT=WITH DRIVER, NON-REFLECTIVE/ABSORPTIVE

ALL DIMENSIONS ARE IN INCHES TOLERANCES:

- X.XX ±0.020
- X.XXX ±0.010

APPROVALS		DATE	AMERICAN MICROWAVE CORPORATION FREDERICK, MARYLAND	
DRAWN		1/23/98	TITLE	
CHECKED		1/28/98	OUTLINE DRAWING	
ISSUED			MSNC-4DR/DT-04T-STANDARD	
			REFLECTIVE OR NON-REFLECTIVE/ABSORPTIVE	
			SOLID STATE SWITCH	
SIZE	FSCM NO.	DWG NO.	REV.	
A	60483	100-4219-1		
SCALE N/S			SHEET 1 of 1	

REVISIONS				
ZONE	REV.	DESCRIPTION	DATE	APPROVED
		ORIGINAL RELEASE	1/23/98	